

UTTARPARA-KOTRUNG MUNICIPALITY

N.I.Q. NO - UKM/013/PHC/2021-22

DATED - 21.01.2022

Memo No. 6/328

Dated - 21.01.2022

Sealed quotations are invited from bona fide Agencies for the work - Supply of 01 no. 240 ltrs. capacity two wheeled HDPE Waste Bin at Uttarpara-Kotrung Municipality.

Sl No. Specification of Item

1. Wheeled waste bin with elegant designed, one piece molded plastics bin of 240 ltrs. capacity manufacture out of the art rotational molding process manufacture from High-density polyethylene (HDPE) with FDA approved material confirming to the requirement of IS 10146-1982; provided fully openable top lid & 2 nos. of HDPE wheels to satisfy the Solid Waste Management.

Dimensions - Weights - Standards

- Nominal volume : 240 liters
- Net weight : approx 13 kg
- Max load : 96 kg
- Permitted total weight : 110 kg
- Brand : Supreme/Nilkamal/Otto

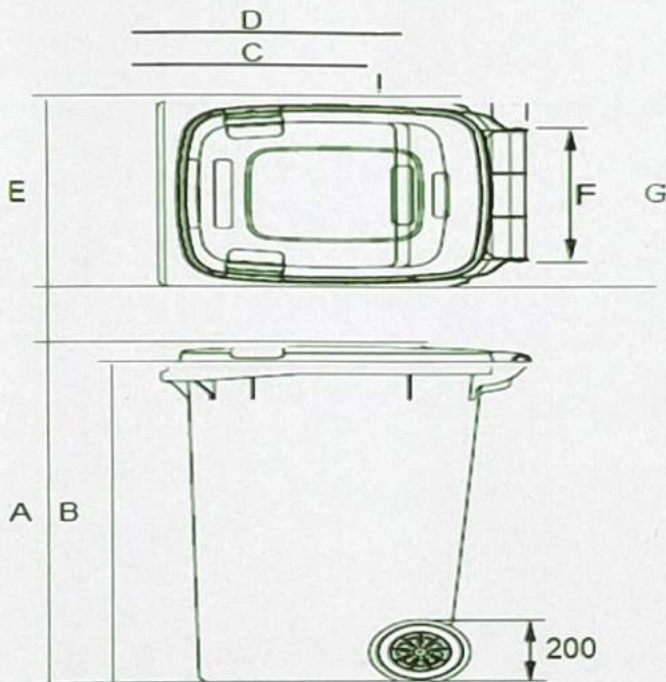

- | | | | | | |
|-----|---------|---|--------|---|--------|
| • A | 1060 mm | D | 730 mm | G | 550 mm |
| • B | 990mm | E | 585 mm | | |
| • C | 660 mm | F | 400 mm | | |

Quotations are to be submitted to the undersigned up to 12.00 pm. on 29.01.2022 which will be opened on the same day after 02.00 pm. Application, in duplicate, enclosing single photo copy of Valid Pan issued by the I.T. Dept., Govt. of India, Valid 15 digit Goods and Services Tax payer identification Number (GSTIN) under GST Act, 2017 and Trade License etc."Tax invoice(s) needs to be issued by the supplier for raising claim under the contract showing separately the tax charged in accordance with the provisions of GST Act, 2017". As instructed by Govt. of West Bengal vide Memo No. 4374/F(Y) Dt. 13-07-2017.

Dilip Yadav

Chairperson
Board of Administrators
Uttarpara-Kotrung Municipality
Chairperson
Board of Administrators
Uttarpara-Kotrung Municipality